



BRITA

TOTAL 360™

Model BRDPFS

How to install, operate
and maintain your
Single Stage Drinking Water
Filtration System

PRODUCT AND WARRANTY REGISTRATION

Register your product
online to validate and
extend your warranty.
See warranty page for
details.



warranty.ecopurehome.com/brita

If you have any questions or concerns when
installing, operating or maintaining your water
filtration system, call our toll free number:

1-800-218-6172

or visit www.ecopurehome.com/brita

When you call, please be prepared to provide
the model number and date code of
your product, found inside the top cover.

System tested and certified by NSF International
against NSF/ANSI Standards 42, 53 and 401
for the reduction of claims specified on the
performance data sheet at www.nsf.org
System tested and certified to CSA B483.1 and
NSF/ANSI/CAN 372.

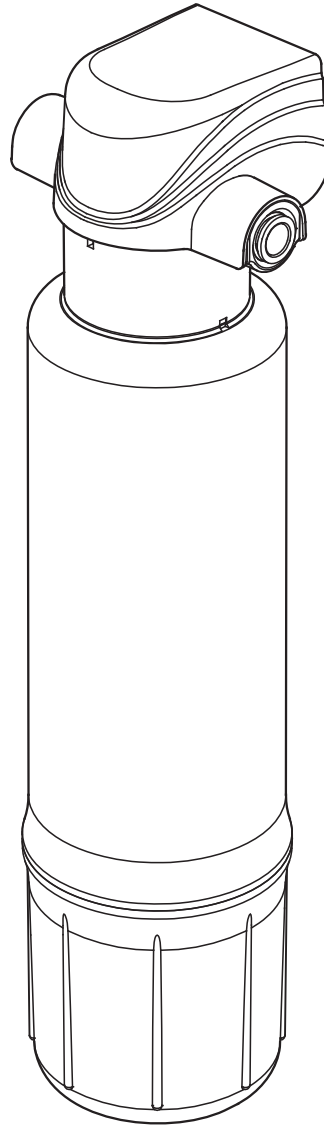

Installation and Operation Manual

Manufactured by
Water Channel Partners
1890 Woodlane Drive
Woodbury, MN 55125

7379612 (Rev. F 4/16/24)

TABLE OF CONTENTS

	<u>Page</u>
Before You Start	3
Specifications & Dimensions	3
Parts & Tools	4
Typical Undersink Installation	4
Installation Instructions	5-6
Step A - Install Water Supply Fittings	5
Step B - Make Tubing Connections	5-6
Step C - Turn On Water, Check for Leaks and Rinse Carbon Fines	6
Filter Cartridges	7
Filter Cartridge Life	7
Filter Cartridge Replacement	7
Troubleshooting the System	8
Exploded View & Parts List	8
Warranty	9
Performance Data	10

Before You Start

- ▼ **Read all steps and guides carefully before installing and using your Single Stage Drinking Water Filtration System.** Follow all steps exactly to correctly install. Reading this manual will also help you to get all the benefits from the water filtration system.
- ▼ **Do not use with water that is microbiologically unsafe or of unknown quality without adequate disinfection before or after the system.** This system is certified for cyst reduction and may be used on disinfected waters that may contain filterable cysts.
- ▼ **All plumbing should be done in accordance with local codes and requirements.** In Massachusetts, plumbing code 248 CMR 3.00 and 10.00 shall be adhered to. Consult with your licensed plumber.
- ▼ **The Single Stage Drinking Water Filtration System works on water pressures of 30 psi (minimum) to 100 psi (maximum).** If your house water pressure is over the maximum, install a pressure reducing valve in the water supply pipe to the filter system.
- ▼ **Do not install the water filtration system outside, or in extreme hot or cold temperatures.** Temperature of the water supply to the filter system must be between 40°F and 100°F. Do not install on hot water.

Specifications & Dimensions

Supply Water Pressure Min. - Max.	30 - 100 psi (207 - 689 kPa)
Supply Water Temperature Min. - Max.	40 - 100 °F (4 - 38 °C)
Rated Service Flow	1.8 gallons per minute (6.8 liters per minute)
Inlet - Outlet	3/8" quick connect fittings and tubing included

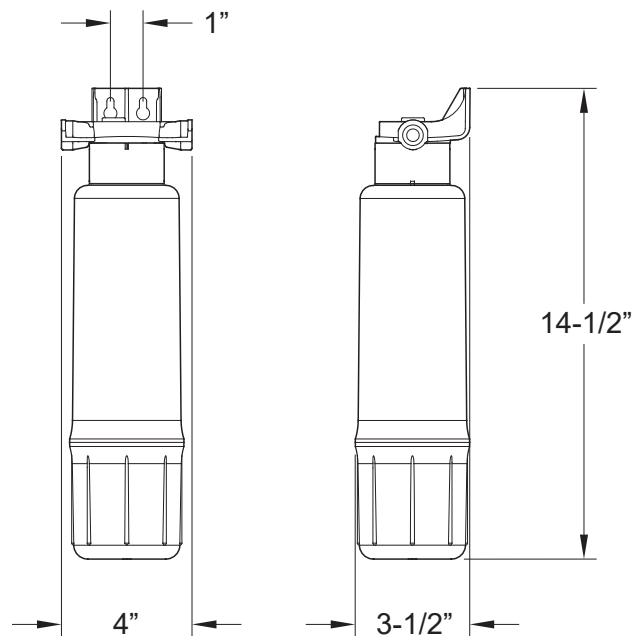

FIG. 1

Questions? Call Toll Free 1-800-218-6172 or visit www.ecopurehome.com/brita

When you call, please be prepared to provide the model number and date code, found inside the top cover.

Parts & Tools

Included:

- Water filter head / bracket
- Top cover
- Filter cartridge
- Tubing
- Bag containing installation parts and mounting screws

Not Included:

- Slotted and Phillips screwdrivers
- Pliers and adjustable jaw wrench
- Tubing cutter
- Electric drill
- Thread sealing tape

Typical Undersink Installation

Locate the water filter housing on the cold water supply pipe, under the kitchen and/or bathroom sink, to filter the cold water. Refer to the following drawing.

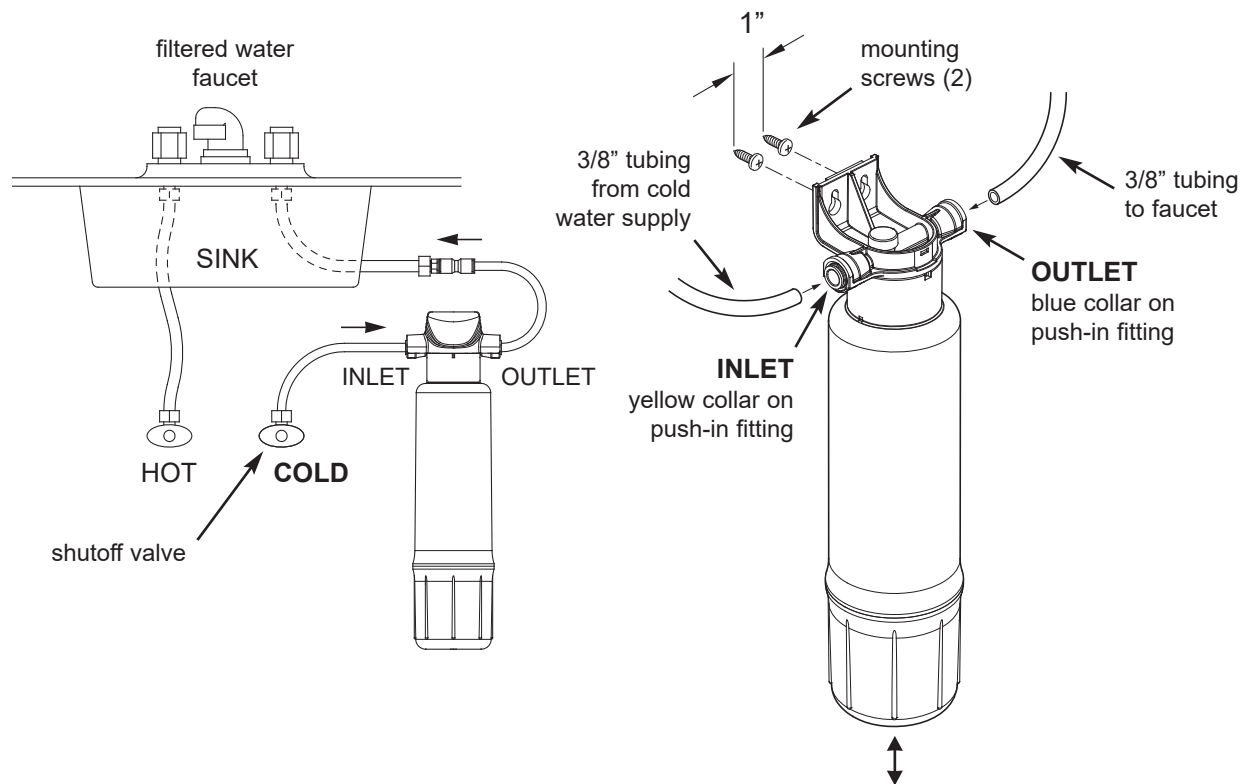

NOTE: Be sure to allow a minimum space of 1-1/2" under the water filter for removing the filter cartridge to change it.

FIG. 2

Installation Instructions

Step A - Install Water Supply Fittings

Check and **comply with local plumbing codes** as you plan, then install the fittings to connect the Single Stage Drinking Water Filtration System into the sink's cold water supply line. Fittings (9/16-24 thread) and 3/8" O.D. tubing are included to provide connections to and from the water filter's inlet and outlet. A typical connection using the included water supply fittings is shown in Figure 3.

1. **Close the sink's water shut off valve(s)**, or another shut off valve upstream from where you will install the water filter, **and open faucets** to relieve pressure from the sink's cold water supply line.
2. Locate the line connecting the cold water shutoff to the sink faucet. Typically this line will be a flexible hose. Disconnect the nut that connects this line to the cold water shutoff. Use a bucket to catch water that drains from this line.
3. Locate one piece of the supplied 3/8" tubing, plus the supplied compression nut, ferrule and tubing insert (See Fig. 3). Assemble the parts onto the tube, as shown in Figure 3, and thread the compression nut onto the cold water shutoff. Tighten to provide a leak-tight connection.
4. Locate the water supply adaptor (supplied) and install it into the nut on the supply line which you disconnected in Step 2. Refer to Figure 3.
5. Press the stem of the water supply adaptor into one end of the supplied union connector (See Figure 3). Be sure to push the stem all the way in.

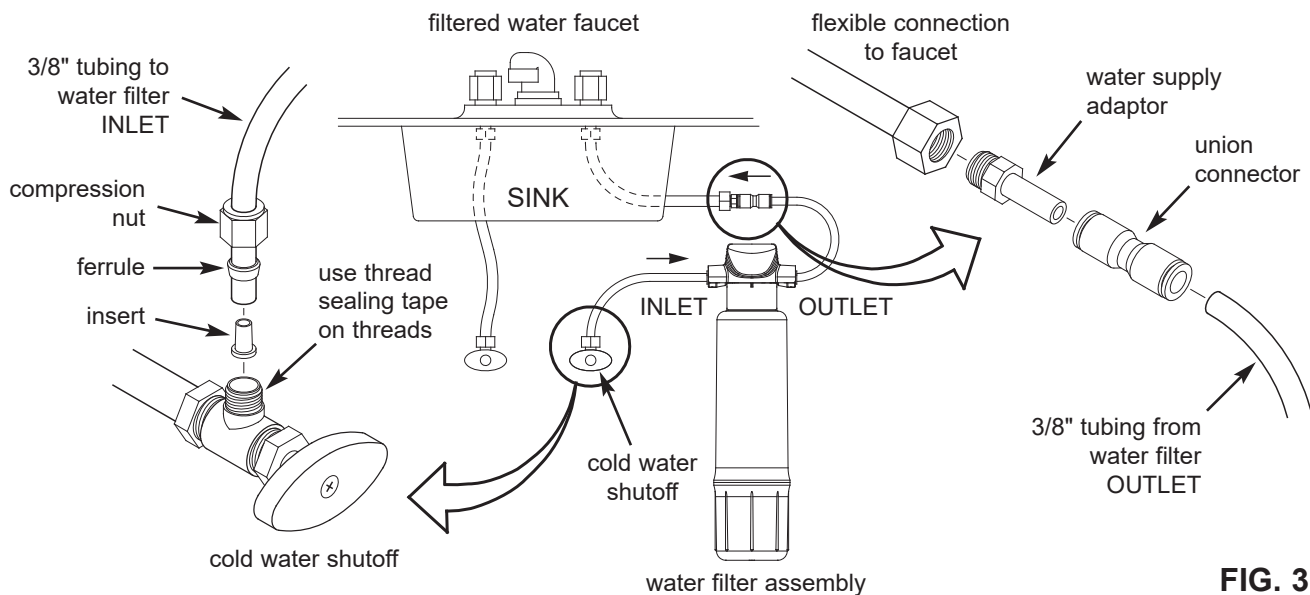

FIG. 3

Step B - Make Tubing Connections

1. Locate the piece of supplied 3/8" tubing not used previously. Route it between the union connector and the water filter outlet (See Figures 2 & 3). Allowing some slack, measure and cut to length. Cut the ends of the tubing square.
2. Insert tubing all the way into the union connector and water filter outlet. Pull on the tubing to be sure that it's held firmly in the fittings.
3. Repeat steps 1 and 2 to connect the tube installed on the cold water shutoff to the water filter inlet.

Tubing Connection (all push-in fitting locations):

This system includes push-in fittings for quick tubing connections. When working with the fittings, do the following.

continued on the next page

Installation Instructions

continued from the previous page

Connect Tubing:

1. Use a tube cutter to cut the end of tubing square.
2. Inspect the end (about 1") of the tubing to be sure there are no nicks, scratches or other rough spots. If needed cut the tubing again.
3. Push tubing through the collet and all the way into fitting. Full engagement is 3/4" length of tube into the fitting.

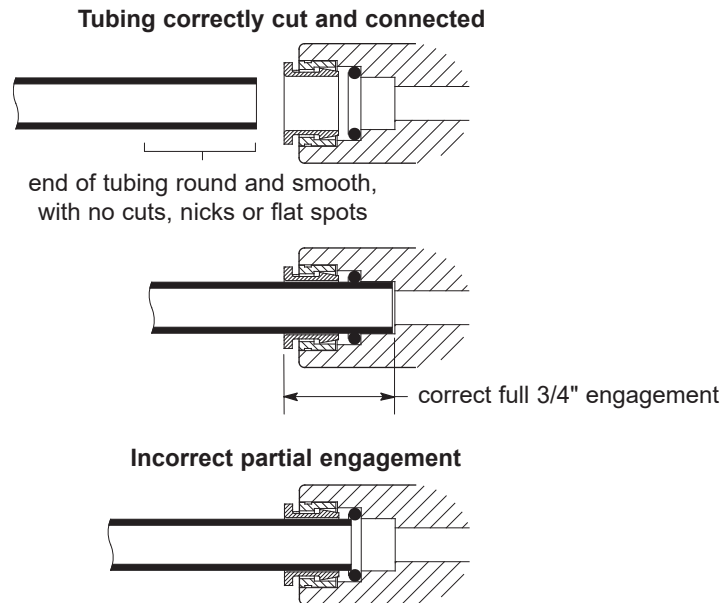

FIG. 4

To Disconnect Tubing:

1. Push the collet inward and hold with a finger while pulling the tubing out.

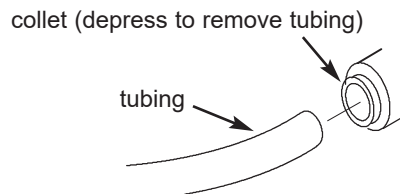

FIG. 5

Step C - Turn On Water, Check for Leaks and Rinse Carbon Fines

1. Open the shutoff valve(s) that you closed at the beginning of this installation.
2. Open the filtered water faucet to purge air from the system. When the water runs smooth, with no bubbles or spurting, close faucet and check installation for leaks.
3. Open the filtered water faucet and let water run for 20 minutes to rinse out carbon fines.

Filter Cartridges

Filter Cartridge Life

Filter Cartridges: A filter cartridge contains activated carbon. When new, open the filtered water faucet and allow fine, carbon particles to purge from the cartridge. Flush for 20 minutes. It is recommended to **replace filter cartridge every six months** of use. There are several variables that determine how long a cartridge will last. These include:

1. How much water you use, and
2. How much sediment, taste and/or odor, or other unwanted substance, is in the water.

Use the following information as a guide. However, no matter which type of cartridge you are using, you will know it is time to replace them when you first notice the return of the unwanted sediment, taste and/or odor in your water, or when the flow diminishes or stops.

Brita Single Stage Water Filtration System model BRDPFS with replacement element BRDPFF conforms to NSF/ANSI 42, 53 and 401 for the specific performance claims as verified and substantiated by test data. The rated capacity for this system is 2000 gallons (7570 liters) at a rated service flow of 1.8 gallons per minute (6.8 liters per minute).

**Register for reminders to change filters at
www.ecopurehome.com/brita**

Filter Cartridge Replacement

NOTE: There is no need to shut off the water supply when replacing the filter cartridge.

1. Turn filter cartridge to the left to remove cartridge from the filter head.
2. Dispose of the cartridge in a proper manner.
3. Install new cartridge. Turn cartridge to the right to re-attach to the filter head.

Filter Cartridges: Filter cartridges contain activated carbon, a black powder. When new, open the filtered water faucet and allow fine, carbon particles to purge from the cartridge. Flush for 20 minutes.

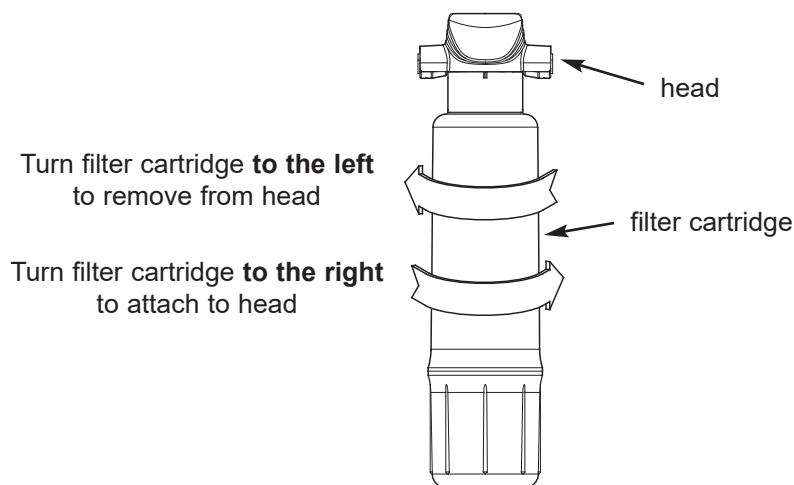

FIG. 6

Questions? Call Toll Free 1-800-218-6172 or visit www.ecopurehome.com/brita

When you call, please be prepared to provide the model number and date code, found inside the top cover.

Troubleshooting the System

Problem: Taste and/or Odor.	
Cause: Filter cartridge exhausted.	Correction: Replace filter cartridge.
Cause: System contaminated.	Correction: Sanitize system. Call 1-800-218-6172 for instructions.
Problem: Water leaks at push connect fittings.	
Cause: Tubing not pushed in all the way.	Correction: Push tubing in all the way into fittings.
Cause: Tubing not cut square.	Correction: Cut tubing square.
Cause: Tubing nicked.	Correction: Remove nicked portion, reinsert tubing into fitting.
Cause: Outer tubing surface not smooth.	Correction: Remove rough portion, reinsert tubing into fitting.

Parts List

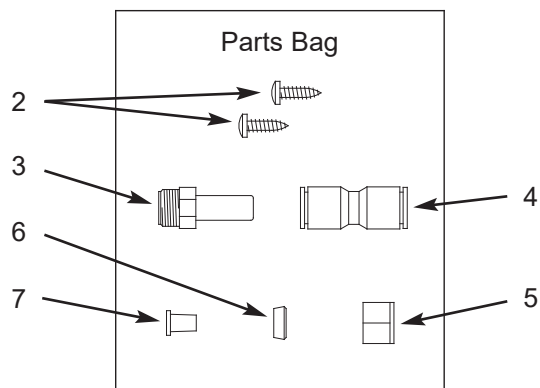
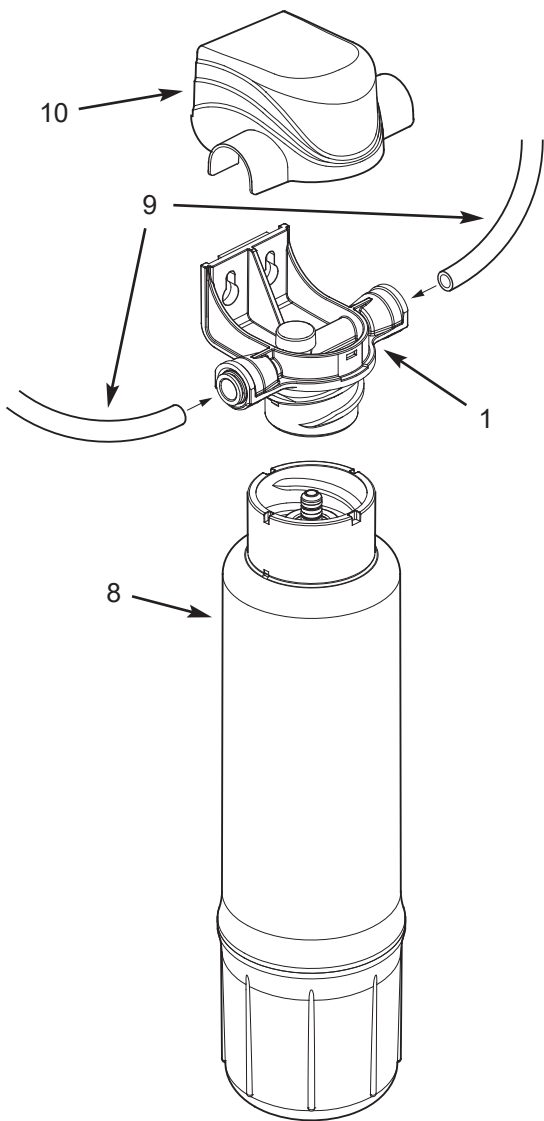

Key No.	Part No.	Description
1	1042-45-HA	Head Assembly with Quick Connect Fittings
-	1042-45-AC	Parts Bag (includes Key Nos. 2-7)
2	↑	Mounting Screws (2)
3	↑	Water Supply Adaptor
4	↑	Union Connector, 3/8" to 3/8"
5	↑	Compression Nut, 3/8"
6	↑	Ferrule, Plastic, 3/8"
7	↑	Tubing Insert, 3/8"
8	BRDPFF	Repl. Filter Cartridge, Taste & Odor *
9	7168435	Tubing, 3/8" OD x 72" long, White
10	7380540	Top Cover

* Please purchase replacement cartridges from the e-commerce retailer where you bought your water filtration system or www.ecopurehome.com/brita.

Manufactured by
Water Channel Partners
1890 Woodlane Drive
Woodbury, MN 55125
1-800-218-6172

To order repair parts visit www.ecopurehome.com/brita

EXTEND YOUR WARRANTY:

You can turn your water filtration system's one year factory warranty into a lifetime warranty by registering the system at warranty.ecopurehome.com/brita and saving your receipts for purchases of Brita replacement filter cartridges. See "Lifetime Warranty" below for details.

WARRANTY

SINGLE STAGE DRINKING WATER FILTRATION SYSTEM - MODEL BRDPFS (not including filter cartridges)

Warrantor: Water Channel Partners, 1890 Woodlane Drive, Woodbury, MN 55125

One Year Warranty:

Warrantor guarantees, to the original purchaser when the product is purchased from an authorized dealer, and when installed and maintained in accordance with the instructions, that the Single Stage Drinking Water Filtration System (BRDPFS) will be free from defects in materials and workmanship and will perform in accordance with its written specifications for a period of one (1) year from the date the product is delivered.

Lifetime Warranty:

Warrantor guarantees, to the original purchaser only, that the Single Stage Drinking Water Filtration System (BRDPFS) will be free from defects in materials and workmanship and will perform in accordance with its written specifications for the lifetime of the purchaser, provided that:

- The product is purchased from an authorized dealer.
- The system is installed and maintained in accordance with the instructions in the same home where it was originally installed.
- The purchaser replaces the filter every six (6) months and saves their receipts, for proof of purchase of the Brita BRDPFF filter cartridge, in case a warranty claim is made. Purchase of no more than two (2) BRDPFF filter cartridges in a 12 month period may be applied toward compliance with this warranty.

Failure to adhere to the above requirements from the date the product is delivered voids the lifetime warranty.

If, during such respective period, a part proves, after inspection, to be defective, Warrantor will, at its sole option, either replace or repair the part without charge except normal shipping and installation charges. If a repair or replacement part is unavailable, Warrantor may refund the original purchase price. Labor necessary to maintain this product is not covered by the product warranty. Filters, which are expendable, are not covered by the warranty.

If you have questions regarding a warranted product, need assistance with installation or troubleshooting, wish to order a part or report a warranty issue, we are just a phone call away. SIMPLY DIAL 1-800-218-6172 for assistance.

General Provisions

The above warranties are effective provided the Single Stage Drinking Water Filtration System is operated at water pressures not exceeding 100 psi (7.0 kg/cm²), and at water temperatures not exceeding 100°F (38°C); provided further that the Single Stage Drinking Water Filtration System is not subject to abuse, misuse, alteration, neglect, freezing, accident or negligence; and provided further that the Single Stage Drinking Water Filtration System is not damaged as the result of any force of nature such as, but not limited to, flood, hurricane, tornado or earthquake.

The limited warranty does not cover damage due to: (a) transportation, (b) storage, (c) improper use, (d) failure to follow the product instructions or to perform any preventive maintenance, (e) modifications, (f) unauthorized repair, (g) normal wear and tear, or (h) external causes such as accidents, abuse, or other actions or events beyond Warrantor's reasonable control. Use of aftermarket, used, or non-manufacturer provided parts will void all warranties. Warranty does not cover failures due to improper product installation. Warrantor is excused if failure to perform its warranty obligations is the result of strikes, government regulation, materials shortages, or other circumstances beyond its control.

THERE ARE NO WARRANTIES ON THE SINGLE STAGE DRINKING WATER FILTRATION SYSTEM BEYOND THOSE SPECIFICALLY DESCRIBED ABOVE. ALL IMPLIED WARRANTIES, INCLUDING ANY IMPLIED WARRANTY OF MERCHANTABILITY OR OF FITNESS FOR A PARTICULAR PURPOSE, ARE DISCLAIMED TO THE EXTENT THEY MIGHT EXTEND BEYOND THE ABOVE PERIODS. THE SOLE OBLIGATION OF WARRANTOR UNDER THESE WARRANTIES IS TO REPLACE OR REPAIR THE COMPONENT OR PART WHICH PROVES TO BE DEFECTIVE WITHIN THE SPECIFIED TIME PERIOD, AND WARRANTOR IS NOT LIABLE FOR CONSEQUENTIAL OR INCIDENTAL DAMAGES. NO DEALER, AGENT, REPRESENTATIVE, OR OTHER PERSON IS AUTHORIZED TO EXTEND OR EXPAND THE WARRANTIES EXPRESSLY DESCRIBED ABOVE.

Some states do not allow the exclusion or limitation of incidental or consequential damages, so the above limitation or exclusion may not apply to you. This warranty gives you specific legal rights, and you may have other rights which vary from state to state. This warranty applies to consumer-owned installations only.

Performance Data

Model BRDPFS Single Stage Drinking Water Filtration System

IMPORTANT NOTICE: Read this performance data and compare the capabilities of this unit with your actual water treatment needs. It is recommended that, before purchasing a water treatment unit, you have your water supply tested to determine your actual water treatment needs. This filter system is designed to be used for the reduction of the performance claims listed below. Do not use where water is microbiologically unsafe or of unknown quality, without adequate disinfection before or after the system. Systems certified for cyst reduction may be used on disinfected water that may contain filterable cysts. While testing was performed under standard laboratory conditions, actual performance of this system may vary based on local water conditions. Some or all of the contaminants reduced by this unit may not be in your water supply. See elsewhere in this owner's manual for further instructions on filter cartridge replacement, system installation, operating procedures, and warranty. The maintenance instructions must be followed for the product to perform as indicated below.

PERFORMANCE CLAIMS		
Substance	NSF Required Influent Challenge Level (mg/L) ¹	NSF Max. Permissible Product Water Concentration (mg/L) ¹
Benzene	0.015 ±10%	0.005
Chlorine Taste & Odor	2.0 ±10%	1.0
Cyst	≥50,000 #/mL ²	99.95% ³
Lead @ pH 6.5	0.15 ±10%	0.010
Lead @ pH 8.5	0.15 ±10%	0.010
Mercury @ pH 6.5	0.006 ±10%	0.002
Mercury @ pH 8.5	0.006 ±10%	0.002
Particulate, Class I (0.5 to <1 micron)	10,000 #/mL ²	85% ³
Microplastics (0.5 to <1 micron)	10,000 #/mL ²	85% ³

¹ Milligrams per liter, which is equivalent to parts per million (PPM).

² Particles per milliliter.

³ NSF minimum percent reduction requirement. Acceptance level for this substance is based on percent reduction, rather than maximum effluent concentration.

General Information

This system has been tested according to NSF/ANSI 42, 53 and 401 for reduction of substances listed above. The concentration of the indicated substances in water entering the system was reduced to a concentration less than or equal to the permissible limit for water leaving the system, as specified in NSF/ANSI 42, 53 and 401. The testing was performed using spiked tap water at a flow rate of 1.8 gallons per minute (6.8 L/min.), pH of 7.5 ± 0.5, pressure of 60 psig, and temperature of 68 ± 5°F.

This product is protected by U.S. patent no's: 6,866,704; 6872.311; 7,276,166; 7,296,691; 7,241,388; 7,287,650; 7,566,014; 8,056,733; applicable U.S. patent applications; foreign patents and foreign patent applications.

Installation Requirements

Pressure Range	30-100 psig (207-689 kPa)
Temperature Range	40-100°F (5-38°C)
Service Flow Rate	1.8 GPM (6.8 LPM)
Service Life	2000 gallons (7570 Liters)

Maintenance

Filter cartridges should be replaced every 2000 gallons or six months, whichever comes first. Purchase replacement cartridges from the e-commerce retailer where you bought your water filtration system or www.ecopurehome.com/brita. Replacement filter prices will vary. Estimated cost of replacement filter cartridge BRDPFF ranges from \$70 to \$100.